

PowerPC 440EP

Embedded Processor

With speeds of up to 667 MHz, support for floating-point operations, USB and NAND Flash interfaces, low power dissipation and a small footprint, the PowerPC 440EP embedded processor is ideally suited to a wide range of high-performance applications, including imaging, industrial control, and networking.



Benefits

- Delivers 333 MHz to 667 MHz performance (CPU)
- Single/double-precision floating-point unit for math-intensive applications
- NAND Flash support
- Extensive connectivity by means of on-chip Ethernet, USB, UARTs, IIC, SPI, and PCI
- Offers low power dissipation and small form factor for high-density and power-conscious applications

The PowerPC 440 Core

To enhance overall throughput, the PowerPC 440 superscalar core incorporates a 7-stage pipeline and executes up to two instructions per cycle. Its large 32-KB data cache and 32-KB instruction cache are 64-way set-associative. Versatile configurations enhance performance tuning while optional parity protection preserves data integrity. For additional system performance, the PowerPC 440 core includes dynamic branch prediction and 24 digital signal processing (DSP) instructions, as well as non-blocking caches that can be managed in either write-through or write-back mode.

High Performance FPU

In addition to its powerful 440 core, the PowerPC 440EP includes a high-performance FPU. This superscalar FPU supports both single and double precision operations, and offers single cycle throughput on most instructions. The result is exceptional performance in imaging and other calculation-intensive applications.

High-Speed Bus Architecture

Offering a peak bandwidth of 4.2 GB/s and separate read and write data buses – the PowerPC 440EP's processor local bus (PLB) provides a high-bandwidth connection between the processor core and memory controller. Less demanding I/O devices are served by a 30-bit on-chip peripheral bus (OPB).

Extensive Memory Support

An on-chip double data rate (DDR) SDRAM controller provides a 32-bit memory interface with optional error checking and correcting (ECC) and a 1.1-GB/s peak data rate. It supports four memory banks of up to 256 MB each, for a maximum capacity of 1 GB.

An integrated NAND Flash controller allows up to four banks of Flash memory devices to be connected to the processor's external peripheral bus. The Flash controller supports device densities up to 512 MB, an optional SmartMedia card interface. These devices can be accessed much like diskette drives, with available boot capability.

PCI Interface

The PowerPC 440EP offers a 32-bit PCI V2.2 interface and supports frequencies of up to 66 MHz. Multiple read prefetch and write post buffers enhance throughput, while the ability to boot the processor from PCI bus memory increases functionality.

Dual Ethernet Ports

For extensive connectivity options, the PPC440EP offers two integrated 10/100 Ethernet ports.

USB Interface

The PPC440EP includes USB 1.1 host and device controllers and a USB 2.0 device controller. The PHY for the USB 1.1 interfaces is included on-chip, while the USB 2.0 interface utilizes an external PHY.

Standard Peripherals

The PPC440EP offers two serial ports, support for up to 64 general purpose I/O (GPIO) and two IIC controllers. A serial peripheral interface (SPI), also referred to as a serial communications port (SCP), allows full-duplex, synchronous data exchanges with other serial devices. The 440EP also supports up to four UARTs in a variety of configurations. A JTAG interface is provided for debugging purposes.

PowerPC Partners Ecosystem

AMCC's embedded PowerPC processors are supported by an extensive ecosystem of products and services from a wide range of leading suppliers. AMCC's PowerPC Partners program includes industry-standard providers of:

- Embedded operating systems
- Hardware and software development tools
- Embedded software products and services
- Board-level products
- System design services
- Technical training

For full details of the products and services available through the PowerPC Partners program, or to browse support available for a specific processor, visit:

<http://www.amcc.com/Embedded/Partners>

AMCC also provides an evaluation kit for this PowerPC processor, including an optimized evaluation board as well as sample applications and other software.

PowerPC 440EP

Features

- Speed (frequency): 333 MHz to 667 MHz
- Performance: 2.0 DMIPS/MHz (1,334 Dhrystone MIPS @ 667 MHz peak)
- Five-stage FPU with 2.0MFLOPS/MHz (SP/DP); hardware support for IEEE 754; single-precision and double-precision operation with 32 64-bit floating point registers
- NAND Flash controller supports one to four banks of NAND Flash memory devices; direct interfacing to discrete NAND Flash devices (up to four devices) and SmartMedia Card socket (22-pins); 4MB-256 MB device sizes supported; 512-B + 16-B or 2-KB + 64-B device page sizes supported; DMA support allows direct, no processor-intervention block copy from NAND Flash out to SDRAM; boot-from-NAND supported
- On-chip double data rate (DDR) SDRAM controller with 32-bit interface, 13-bit addressing, 1.1-GB/s peak data rate and optional ECC
- Support for four banks DDR SDRAM memory of up to 256MB each, maximum capacity of 1 GB
- Support for 64, 128, 256, and 512-Mb DDR devices, with CAS latencies of 2, 2.5, or 3
- 32-bit PCI V2.2, 3.3 V interface supporting frequencies up to 66 MHz
- USB 1.1 host and device controllers with on-chip PHYs plus USB 2.0 device controller with UTMI interface to connect to off-chip PHY
- (2) Ethernet 10/100Mb/s, full-duplex MAC (1xMII or 2xRMII) with packet reject interface support; memory access layer (MAL) provides DMA capability to both Ethernet channels
- Up to four serial port UARTs (1x 8-pin, or 2x 4-pin, or 4x 2-pin, or 1x4-pin and 2x 2-pin)
- Two IIC (with one integrated boot strap controller)
- One SPI serial interface 4-channel DMA – available for internal and external use
- Programmable interrupt controller with 10 external inputs, 64 internal inputs
- Programmable timers
- General-purpose I/O (64)
- Support for JTAG board testing, JTAG debuggers, and 4xx instruction trace interface
- RoHS compliant versions available (lead-free)

For more information, please visit <http://www.amcc.com>.

Specifications

Technology	<ul style="list-style-type: none"> • 0.13-μm CMOS
Performance (estimated)	<ul style="list-style-type: none"> • 666 Dhrystone 2.1 MIPS @ 333 MHz • 1,334 Dhrystone 2.1 MIPS @ 667 MHz
Frequency	<ul style="list-style-type: none"> • CPU: 333 MHz to 667 MHz • Memory: 32-bit width: 800 B/s (DDR200) to 1.1 GB/s (DDR266) • PCI: 32 bits, 33 MHz to 66 MHz
Typical Power Dissipation (application dependent)	<ul style="list-style-type: none"> • 2.3 W @ 333 MHz • 2.4 W @ 400 MHz • 2.6 W @ 533 MHz • 3.3 W @ 667 MHz
Case Temperature Range	<ul style="list-style-type: none"> • -40°C to +100°C
Power Supply	<ul style="list-style-type: none"> • 1.5V (logic), 2.5V (SDRAM/Ethernet/USB), 3.3V (PCI, other I/O)
Signal I/Os	<ul style="list-style-type: none"> • 304
Packaging	<ul style="list-style-type: none"> • 456 ball E-PBGA, 35 mm x 35 mm (with 1.27-mm pad pitch) • 456 ball TE-PBGA, 35mm x 35mm (with 1.27-mm pad pitch) <p>Both packages are available in leaded and lead-free (RoHS compliant).</p>

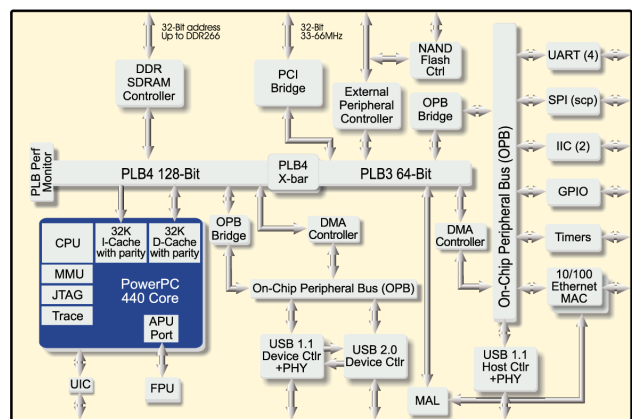

215 Moffett Park Drive
Sunnyvale, CA 94089
P 858 450 9333
F 858 450 9885
www.amcc.com

For technical support, please call 1-800-840-6055 or 858-535-6517, or email support@amcc.com. AMCC reserves the right to make changes to its products, its datasheets, or related documentation, without notice and warrants its products solely pursuant to its terms and conditions of sale, only to substantially comply with the latest available datasheet. Please consult AMCC's Term and Conditions of Sale for its warranties and other terms, conditions and limitations. AMCC may discontinue any semiconductor product or service without notice, and advises its customers to obtain the latest version of relevant information to verify, before placing orders, that the information is current. AMCC does not assume any liability arising out of the application or use of any product or circuit described herein, neither does it convey any license under its patent rights nor the rights of others. AMCC reserves the right to ship devices of higher grade in place of those of lower grade. AMCC SEMICONDUCTOR PRODUCTS ARE NOT DESIGNED, INTENDED, AUTHORIZED, OR WARRANTED TO BE SUITABLE FOR USE IN LIFE-SUPPORT APPLICATIONS, DEVICES OR SYSTEMS OR OTHER CRITICAL APPLICATIONS. AMCC is a registered trademark of Applied Micro Circuits Corporation. PowerPC and the PowerPC logo are registered trademarks of IBM Corporation. All other trademarks are the property of their respective holders. Copyright © 2006 Applied Micro Circuits Corporation. All Rights Reserved. POWERPC440EP_PB_v1.03_02_16_2006